



**ISO 9001 : 2015  
Certified**



**Certified**

## COUPLINGS

The couplings used with glass equipment are important from two main points of view :

- ↺ They must ensure the effective seal of the joint.
- ↺ They should not induce any undue stress in the glass.
- ↺ They must be reliable in all service conditions.

In this section we have covered couplings to join glass components together as well as to join glass components with a other metal equipments

PTFE bellows are available for normal and vacuum applications together with flanges to connect them to glass or non-glass equipment.

## STRUCTURE & SUPPORTS

Glass plants are normally supported in a tubular structure formed of galvanised steel tubes. This type of structure is proven robust and flexible over many years.

## COMPLETE COUPLINGS

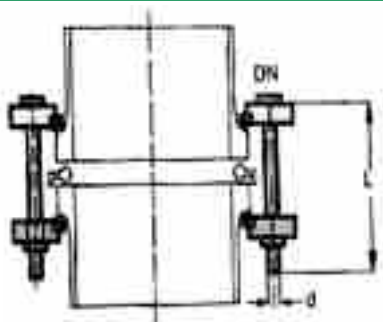

Flanges		Inserts		Nuts- Bolts				
Cat. Ref.	DN	Cat. Ref.	Qty.	Cat. Ref.	Qty.	d	L	Qty.
BCT1	25	BCF1	2nos	BCN1	2nos	5/16"	65	3nos
BCT1.5	40	BCF1.5	2nos	BCN1.5	2nos	5/16"	65	3nos
BCT2	50	BCF2	2nos	BCN2	2nos	5/16"	75	3nos
BCT3	80	BCF3	2nos	BCN3	2nos	5/16"	75	6nos
BCT4	100	BCF4	2nos	BCN4	2nos	5/16"	100	6nos
BCT6	150	BCF6	2nos	BCN6	2nos	5/16"	100	6nos
BCT9	225	BCF9	2nos	BCN9	2nos	3/8"	125	8nos
BCT12	300	BCF12	2nos	BCN12	2nos	3/8"	150	12nos
BCT16	400	BCF16	2nos	BCN16	2nos	3/8"	150	12nos
BCT18	450	BCF18	2nos	BCN18	2nos	1/2"	150	12nos
BCT24	600	BCF24	2nos	BCN24	2nos	1/2"	150	12nos

A complete coupling is a set of two backing flanges with insert and nut-bolts. It is a complete set of flanges require to make a joint.

## BACKING FLANGES

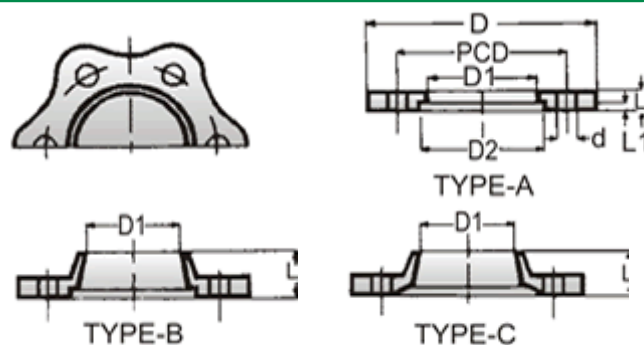

Cat. Ref.	DN	D	D1	D2	PCD	nxdo	L	L1	Type
BCF1	25	92	43	51	70	3x90	10	6	A
BCF1.5	40	110	58	66	86	3x90	10	6	A
BCF2	50	120	70	81	98	3x90	12	8	A
BCF3	80	155	101	112	133	6x90	12	8	A
BCF4	100	200	134	148	178	6x90	12	8	A
BCF6	150	275	186	196	254	6x90	15	8	A
BCF9	225	350	260	282	310	8x110	28	8	B
BCF12	300	425	342	363	395	12x110	34	8	B
BCF16	400	525	467	476	495	12x120	22	8	A
BCF18	450	630	537	557	585	12x140	38	8	B
BCF24	600	755	643	690	710	12x140	50	5	C

Backing flanges are used to couple a glass ends to a glass end or to a bellow. Backing flanges are made of cast iron and are used with inserts.

## INSERTS

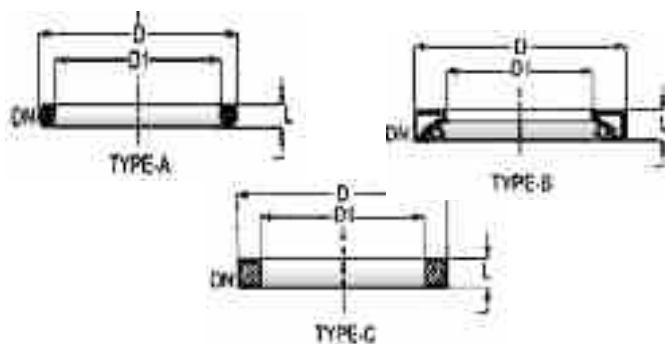

Cat. Ref.	DN	D	D1	L	Type
BCN1	25	50	34	10	A
BCN1.5	40	65	48	10	A
BCN2	50	80	61	8	B
BCN3	80	111	90	9	B
BCN4	100	147	119	10	B
BCN6	150	195	168	10	B
BCN9	225	280	240	10	B
BCN12	300	361	324	10	B
BCN16	400	474	431	12	B
BCN18	450	555	500	18	B
BCN24	600	684	634	10	C

Split ring type inserts are used with backing flanges. These are made of Cast Iron with asbestos lining. New inserts made of suitable composite rubber material are being introduced and are presently supplied for 25 and 150 DN size.

## ADAPTOR BACKING FLANGES

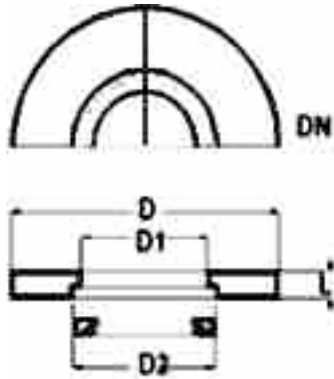

### Undrilling flanges

Cat. Ref.	DN	D	D1	D2	L
BCFA1	25	115	43	51	10
BCFA1.5	40	150	58	66	10
BCFA2	50	165	70	81	12
BCFA3	80	200	101	112	12
BCFA4	100	220	134	148	12
BCFA6	150	285	186	196	15
BCFA9	225	395	260	282	15
BCFA12	300	445	342	363	18

### Drilled to Table E

Cat. Ref.	PCD	n x dØ
BCFA1/E	82	4 x 12Ø
BCFA1.5/E	98	4 x 12Ø
BCFA2/E	114	4 x 16Ø
BCFA3/E	146	4 x 16Ø
BCFA4/E	178	8 x 16Ø
BCFA6/E	235	8 x 16Ø
BCFA9/E	324	12 x 19Ø
BCFA12/E	406	12 x 23Ø

### Drilled to Table F

Cat. Ref.	PCD	n x dØ
BCFA1/F	87	4 x 16Ø
BCFA1.5/F	105	4 x 16Ø
BCFA2/F	127	4 x 16Ø
BCFA3/F	165	8 x 16Ø
BCFA4/F	190	8 x 16Ø
BCFA6/F	260	12 x 19Ø
BCFA9/F	356	12 x 23Ø
BCFA12/F	438	16 x 23Ø

### Drilled to ASA 150

Cat. Ref.	PCD	n x dØ
BCFA1/A	79	4 x 12Ø
BCFA1.5/A	98	4 x 12Ø
BCFA2/A	121	4 x 16Ø
BCFA3/A	152	4 x 16Ø
BCFA4/A	190	8 x 16Ø
BCFA6/A	241	8 x 19Ø
BCFA9/A	298	8 x 19Ø
BCFA12/A	432	12 x 23Ø

Adaptor backing flanges are used to couple a glass end to the flange having different bolt configuration. These flanges are made of cast iron and are supplied with inserts.

These are particularly used to fit a glass equipment on a non-glass equipment like Glass-lined Reactor etc.

Adaptor backing flanges are generally supplied undrilled. However, if specified, these can be supplied drilled as per "Table E", "Table F" and "ASA 150" standards.

## PTFE "O" RING WITH LOCKING COLLOR

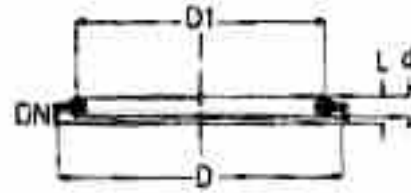

Cat. Ref.	DN	D	D1	d	L
BTR1	25	42	33	3	5
BTR1.5	40	57	48	3	5
BTR2	50	70	59	3	5
BTR3	80	100	88	3	5
BTR4	100	134	119	4	6
BTR6	150	186	168	4	6
BTR9	225	260	236	4	7
BTR12	300	342	318	4	7
BTR16	400	467	435	6	7
BTR18	450	537	490	6	7
BTR24	600	686	640	8	10

These PTFE O rings are specially made to use as gaskets in glass fittings. These are provided with a collar which helps to locate it on the glass end correctly.

## PTFE BELLOWS - GLASS TO GLASS

These bellows are used in installation of glass equipment for following purposes :

- to provide safe branching of pipelines from the main glass equipment
- to accomodate odd degrees and variation in length.

Bellows are supplied alongwith required bellow flanges and nut-bolts. Distance - locking bolts are provided to avoid excessive compression or contraction of the bellow. Gaskets are not required where bellows are used. For drilling details, refer "Bellow flanges."

### Line Bellow

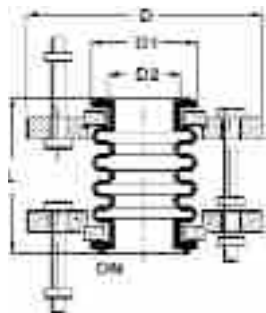

Cat. Ref.	DN	D	D1	D2	L
BFBN1	25	95	41	31	60
BFBN1.5	40	105	56	43	65
BFBN2	50	120	69	55	65
BFBN3	80	155	98	82	65
BFBN4	100	200	132	111	65
BFBN6	150	275	184	162	65
BFBN9	225	350	258	230	65
BFBN12	300	420	340	308	65

These can withstand a temperature of 200°C under normal atmospheric conditions.

### Vacuum Bellow

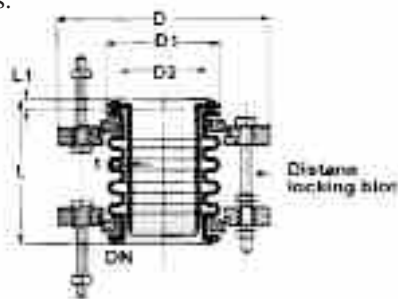

Cat. Ref.	DN	D	D1	D2	L	L1	t
BVB3	80	155	98	92	70	5	3.0
BVB4	100	200	132	111	70	5	3.5
BVB6	150	275	184	162	70	5	4.0
BVB9	225	350	253	230	70	5	5.0
BVB12	300	420	338	308	70	5	5.0

For pipelines of 80DN and above operating under vacuum, the bellows are provided with an internal sleeve which supports the convolutions without affecting the flexibility of the bellow. These bellows can withstand a temperature upto 200oC under full vacuum.

For size upto 50 DN, line bellows can be used for these applications

## PTFE BELLOWS - GLASS TO METAL

These bellows are used in installation of glass equipment for following purposes

- to minimise the transfer of vibrations from the rotating equipments which are connected to the glass assembly.
- to accomodate the thermal expansion of any metallic (non-glass) equipment which are connected to the glass pipeline.

These are similar to the bellows for glass-to-glass in construction, but having a adaptor bellow flange at one end. Generally this adaptor flange is supplied undrilled so that it can be drilled as per the configuration of mating flange. However this adaptor bellow flange can be supplied drilled as per 'Table E' or 'ASA 150' standards, if specified.

### Line Bellow

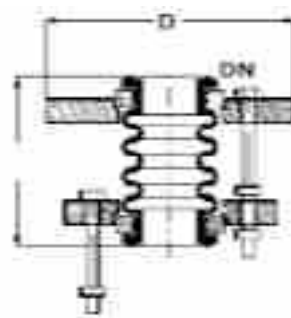

Cat. Ref. Undrilled	Cat. Ref. Table E	Cat. Ref. Table F	Cat. Ref. ASA 150	DN	D	L
BFBF1	BFBF1/E	BFBF1/F	BFBF1/A	25	115	60
BFBF1.5	BFBF1.5/E	BFBF1.5/F	BFBF1.5/A	40	150	65
BFBF2	BFBF2/E	BFBF2/F	BFBF2/A	50	165	65
BFBF3	BFBF3/E	BFBF3/F	BFBF3/A	80	200	65
BFBF4	BFBF4/E	BFBF4/F	BFBF4/A	100	220	65
BFBF6	BFBF6/E	BFBF6/F	BFBF6/A	150	285	65
BFBF9	BFBF9/E	BFBF9/F	BFBF9/A	225	395	65
BFBF12	BFBF12/E	BFBF12/F	BFBF12/A	300	445	65

### Vacuum Bellow

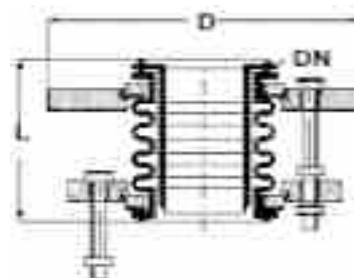

Cat. Ref. Undrilled	Cat. Ref. Table E	Cat. Ref. Table F	Cat. Ref. ASA 150	DN	D	L
BVBF3	BVBF3/E	BVBF3/F	BVBF3/A	80	200	70
BVBF4	BVBF4/E	BVBF4/F	BVBF4/A	100	220	70
BVBF6	BVBF6/E	BVBF6/F	BVBF6/A	150	285	70
BVBF9	BVBF9/E	BVBF9/F	BVBF9/A	225	395	70
BVBF12	BVBF12/E	BVBF12/F	BVBF12/A	300	445	70

## BELLOW FLANGES

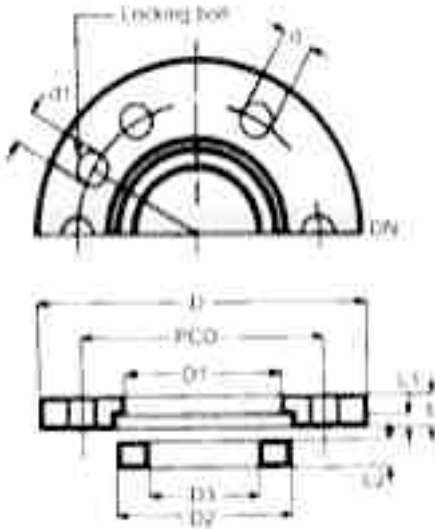

Cat. Ref.	DN	D	D1	D2	D3	L	L1	L2
BBF1	25	95	43	51	33	7	3	6
BBF1.5	40	110	58	66	45	7	3	6
BBF2	50	120	70	81	57	7	3	6
BBF3	80	155	101	112	84	7	3	6
BBF4	100	200	134	148	113	8	3	6
BBF6	150	275	186	196	164	8	3	6
BBF9	225	350	260	282	234	8	3	6
BBF12	300	425	342	363	310	10	5	8

### Drilling details

Cat. Ref.	PCD	n x dØ	n x d1Ø
BBF1	70	3 x 9Ø	2 x 9Ø
BBF1.5	86	3 x 9Ø	2 x 9Ø
BBF2	98	3 x 9Ø	2 x 9Ø
BBF3	133	6 x 9Ø	2 x 9Ø
BBF4	178	6 x 9Ø	2 x 9Ø
BBF6	254	6 x 9Ø	2 x 9Ø
BBF9	310	8 x 11Ø	2 x 11Ø
BBF12	395	12 x 11Ø	2 x 11Ø

Bellow flanges are used to fit a bellow to a glass component. These are made of Cast Iron and are used in FBN, VB, FB type bellows. These are provided with two holes at 180° for distance-looking bolts and are supplied with a split ring.

## ADAPTOR BELLOW FLANGES

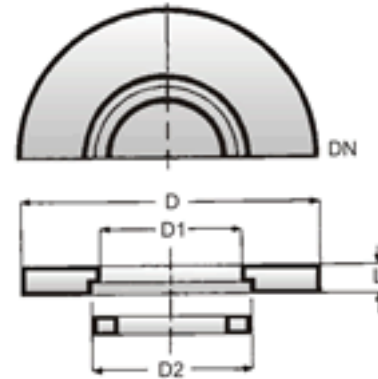

### Undrilling flanges

Cat. Ref.	DN	D	D1	D2	L
BBFA1	25	115	43	51	7
BBFA1.5	40	150	58	66	7
BBFA2	50	165	70	81	7
BBFA3	80	200	101	112	7
BBFA4	100	220	134	148	8
BBFA6	150	285	186	196	8
BBFA9	225	395	260	282	8
BBFA12	300	445	342	363	10

### Drilled to Table E

Cat. Ref.	PCD	n x dØ
BBFA1/E	82	4 x 12Ø
BBFA1.5/E	98	4 x 12Ø
BBFA2/E	114	4 x 16Ø
BBFA3/E	146	4 x 16Ø
BBFA4/E	178	8 x 16Ø
BBFA6/E	235	8 x 16Ø
BBFA9/E	324	12 x 19Ø
BBFA12/E	406	12 x 23Ø

### Drilled to Table F

Cat. Ref.	PCD	n x dØ
BBFA1/F	87	4 x 16Ø
BBFA1.5/F	105	4 x 16Ø
BBFA2/F	127	4 x 16Ø
BBFA3/F	165	8 x 16Ø
BBFA4/F	190	8 x 16Ø
BBFA6/F	260	12 x 19Ø
BBFA9/F	356	12 x 23Ø
BBFA12/F	438	12 x 23Ø

### Drilled to ASA 150

Cat. Ref.	PCD	n x dØ
BBFA1/A	79	4 x 16Ø
BBFA1.5/A	98	4 x 16Ø
BBFA2/A	121	4 x 19Ø
BBFA3/A	152	4 x 19Ø
BBFA4/A	190	8 x 19Ø
BBFA6/A	241	8 x 19Ø
BBFA9/A	298	8 x 19Ø
BBFA12/A	432	12 x 23Ø

Adaptor bellow flange are used to fit a bellow to a flange having different bolt configuration. These flanges are made of cast iron and are supplied with a split ring.

These are particularly used to fit a bellow with a non-glass equipment like Glass-lined Reactor etc. These are used in BBFB, BVBF type PTFE bellows.

Adaptor bellow flanges are generally supplied undrilled. However, if specified, these can be supplied drilled as per 'Table E', 'Table F' and 'ASA 150' standards.